















Thank you for purchasing the Performance Race Track Conference Table.  
 Please follow these instructions for easy assembly.

1  Cam Lock 12 Pcs	2  KD Fitting 2 Pcs	3  Klix Cam 16 Pcs	4  Housing Cap (Long) 10Pcs	5  Housing Cap (Short) 6 Pcs	6  Adjustable Glide 6 Pcs	7  6 Hole L-Bracket 6 Pcs	8  I-Bracket 2 Pcs	9  Screw #8 x 5/8" 48 Pcs
--	---	--	--	---	---	--	--	--

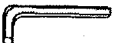
10  Cross Nut M6 x 70mm 4 Sets	11  Ø10mm Hole Plug 22 Pcs	12  M4 x 65 Allen-Key 1 Pc
---	---	--

A  Top Panel x 2	B  Side Panel x 2	C  Center Panel	D  Modesty x 2
---	--	--	---

**KLIX CAM INSTRUCTIONS**

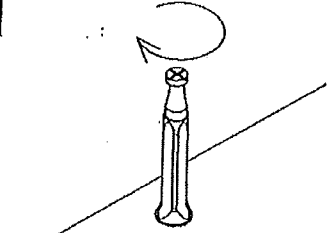
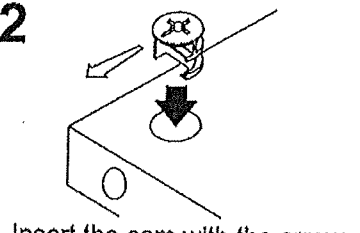
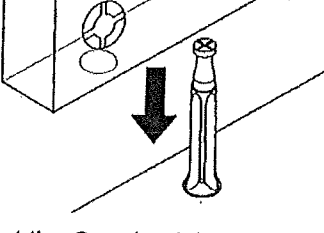
1  Line up Cam Lock, turn clockwise.	2  Insert the cam with the arrow pointing towards the hole in the edge.	3  Insert the Cam Lock into Klix Cam. Turn Klix Cam to lock.
---	---	---

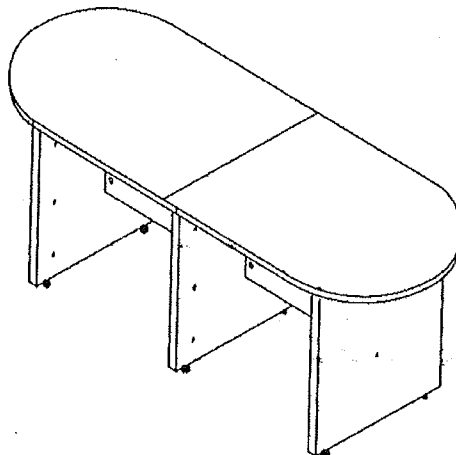

**IMPORTANT NOTE :**

- Place all wooden parts on a clean and smooth surface such as a rug or carpet to avoid the parts from being scratched.
- Check to be sure that you have all parts and hardware.  
 Remove all wrapping materials, including staples & packing straps before you start to assemble.
- Do not tighten all screws/bolts until all completely assembled.
- Keep all hardware parts out of reach of children.



# PL 138 A RACE TRACK CONFERENCE TABLE

