

## RACE TRACK/BOAT SHAPE CONFERENCE TABLE

Thank you for purchasing the Performance Race Track / Boat Shape Conference Table.  
Please follow these instructions for easy assembly.

Option 1

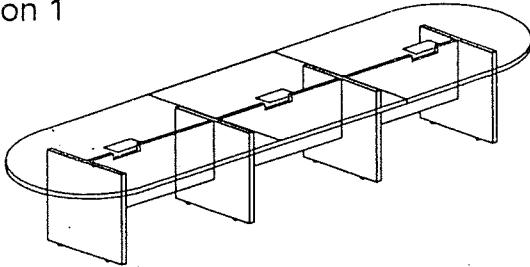

See Page 3

Option 1

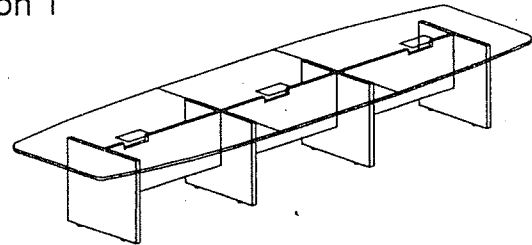

See Page 3

Option 2

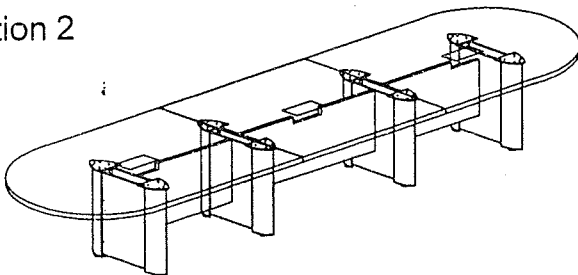

See Page 4

Option 2

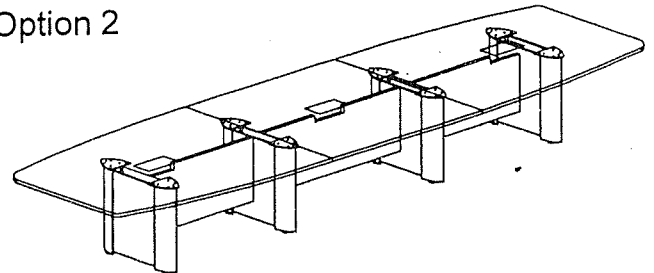

See Page 4

Option 3

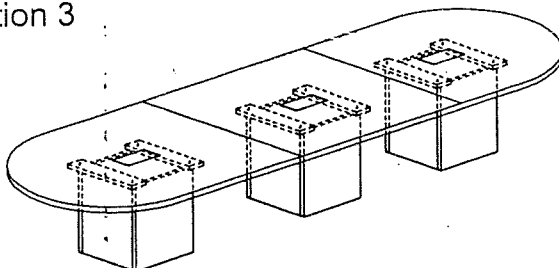

See Page 5

Option 3

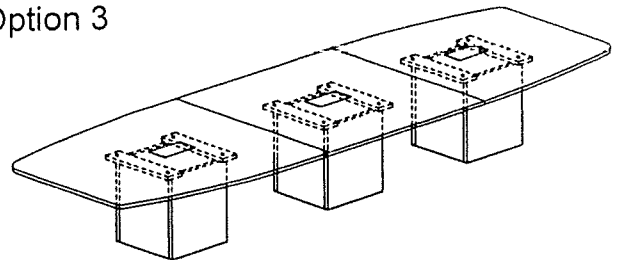

See Page 5

Option 4

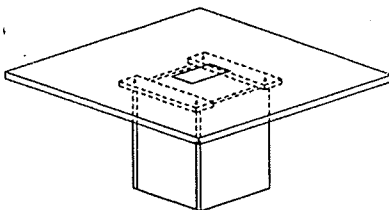

See Page 5

### IMPORTANT NOTE :

- Place all wooden parts on a clean and smooth surface such as a rug or carpet to avoid the parts from being scratched.
- Check to be sure that you have all parts and hardware.
- Remove all wrapping materials, including staples & packing straps before you start to assemble.
- Do not tighten all screws/bolts until all completely assembled.
- Keep all hardware parts out of reach of children.

# RACE TRACK/BOAT SHAPE CONFERENCE TABLE

Thank you for purchasing the Performance Race Track / Boat Shape Conference Table.  
 Please follow these instructions for easy assembly.

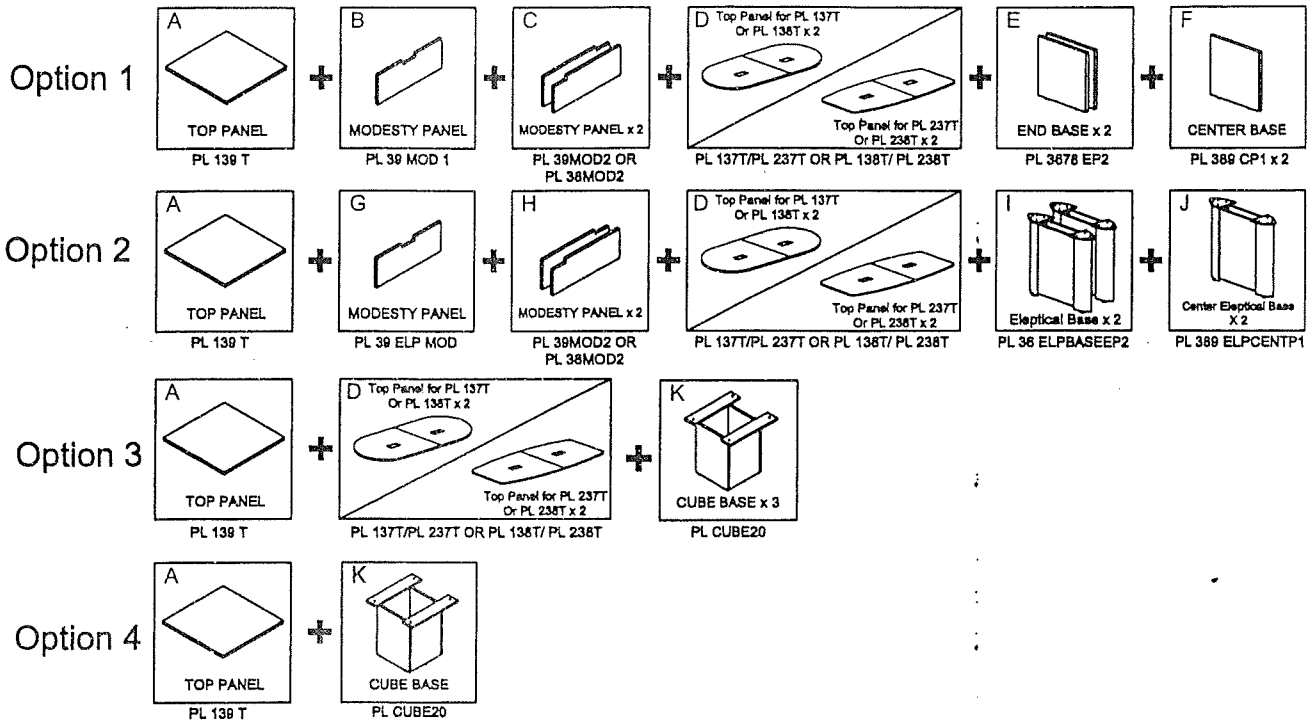

HARDWARE PACK PL 139 T							
A4 6 Hole L-Bracket 5 Pcs	A5 Flat Bracket 6 Pcs	A6 Screw #6 x 3/8" 66 Pcs					
HARDWARE PACK PL 137 T/PL 237 T							
D1 KD Fitting 2 Pcs	D2 Kitx Cam 4 Pcs	D3 Housing Cap (Long) 4 Pcs	D4 6 Hole L-Bracket 6 Pcs	D5 Flat Bracket 2 Pcs	D6 Screw #6 x 3/8" 48 Pcs	D7 Fitting-GL Screw 2 Pcs	D8 Wrench 1 Pc
HARDWARE PACK PL 3678 EP2							
E1 Cam Lock 10 Pcs	E2 Kitx Cam 10 Pcs	E3 Housing Cap (Long) 6 Pcs	E4 Housing Cap (Short) 4 Pcs	E5 Adjustable Glide 4 Pcs	E6 6 Hole L-Bracket 4 Pcs	E7 Screw #6 x 3/8" 24 Pcs	E8 M4 x 65 Allen-Key 1 Pc
HARDWARE PACK PL 389 CP1 x 2							
F1 Cam Lock 6 Pcs	F2 Kitx Cam 6 Pcs	F3 Housing Cap (Long) 4 Pcs	F4 Housing Cap (Short) 2 Pcs	F5 Adjustable Glide 2 Pcs	F6 6 Hole L-Bracket 4 Pcs	F7 Screw #6 x 3/8" 24 Pcs	F8 M4 x 65 Allen-Key 1 Pc
HARDWARE PACK PL 36 ELPBASEEP2							
I1 Cam Lock 6 Pcs	I2 Kitx Cam 6 Pcs	I3 Housing Cap (Long) 6 Pcs	I4 Adjustable Glide 4 Pcs	I5 6 Hole L-Bracket 4 Pcs	I6 Screw #6 x 3/8" 24 Pcs	I7 M4 x 65 Allen-Key 1 Pc	I8 CSK Screw M3.5 x 20MM 16 Pcs
HARDWARE PACK PL 3678 EP2							
J1 Cam Lock 10 Pcs	J2 Kitx Cam 10 Pcs	J3 Housing Cap (Long) 6 Pcs	J4 Housing Cap (Short) 4 Pcs	J5 Adjustable Glide 4 Pcs	J6 6 Hole L-Bracket 4 Pcs	J7 Screw #6 x 3/8" 24 Pcs	J8 M4 x 65 Allen-Key 1 Pc
HARDWARE PACK PL CUBE20							
K1 Cam Lock 16 Pcs	K2 Kitx Cam 16 Pcs	K3 Housing Cap (Long) 16 Pcs	K4 JCSB Screw M6 x 40mm = 4pcs Washer = 4pcs	K5 Adjustable Glide 6 Pcs	K6 M4 x 65 Allen-Key 1 Pc		

# RACE TRACK/BOAT SHAPE CONFERENCE TABLE

## KLIX CAM INSTRUCTIONS

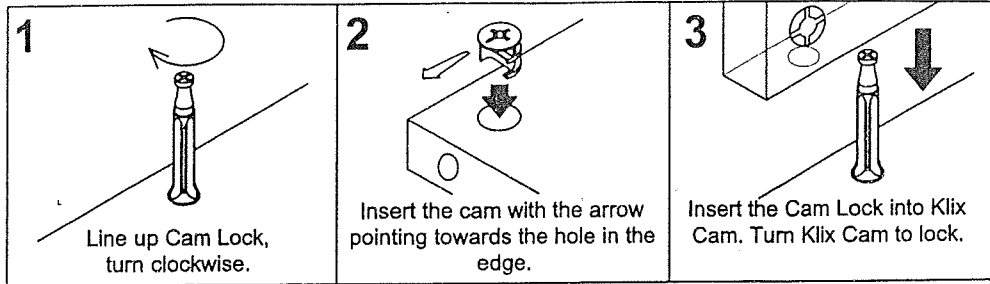

### Option 1

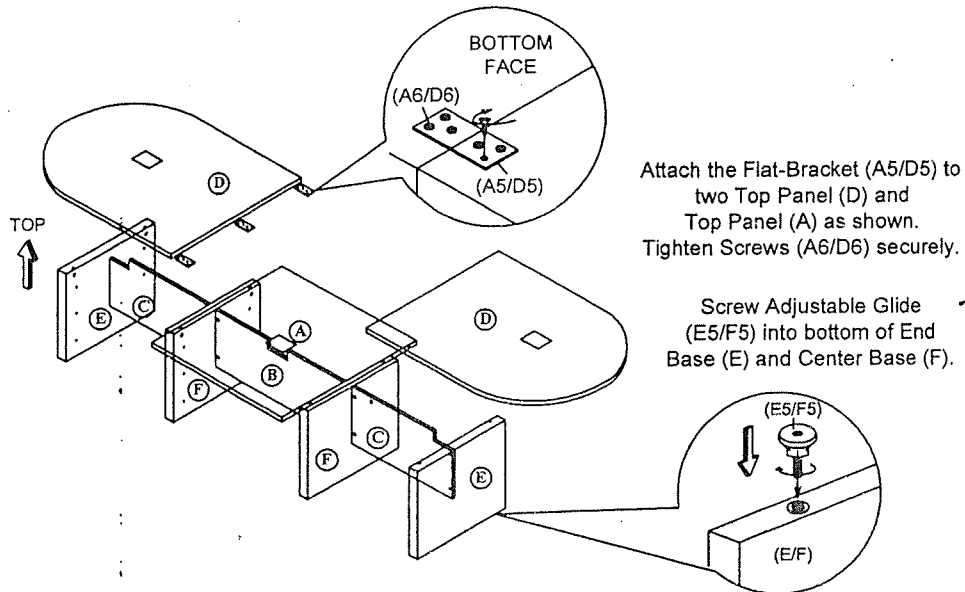

Attach Center Base (F) to Modesty Panel (B) by using Cam Lock (E1/F1) and Klix Cam (E2/F2). Attach Modesty Panel (C) to Center Base (F) by using Cam Lock (E1/F1) and Klix Cam (E2/F2). Attach End Base (E) to Modesty Panel (C) by using Cam Lock (E1/F1) and Klix Cam (E2/F2). Attach Top Panel (A) & Top Panel (D) to Center Base (F) & End Base (E) & Modesty Panel (B/C) by using Cam Lock (E1/F1) and Klix Cam (E2/F2).

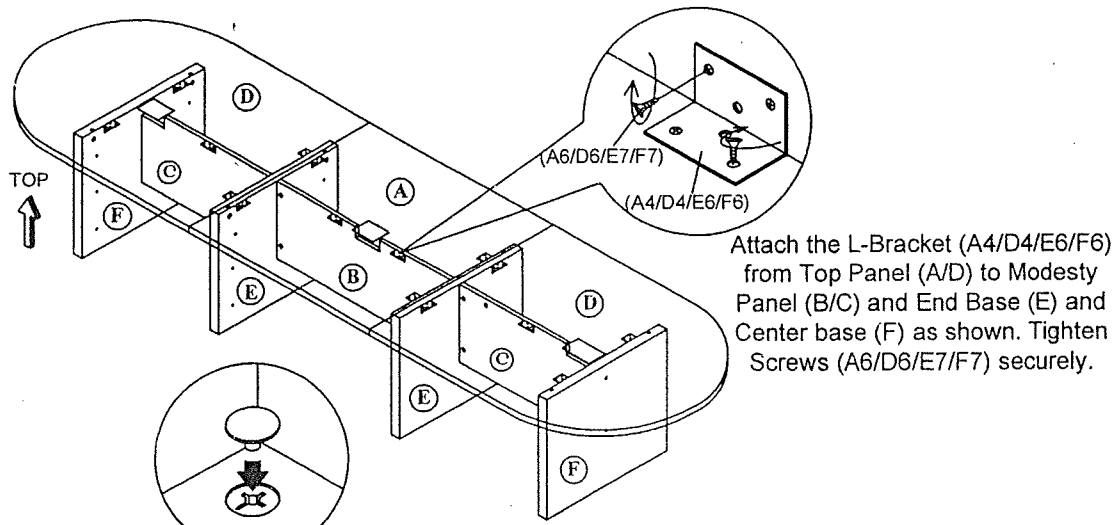

Attach Housing Cap (A3/D3/E3/E4/F3/F4) to all Klix Cam (A2/D2/E2/F2) by pushing neck through center of cam.

**KLIX CAM INSTRUCTIONS**

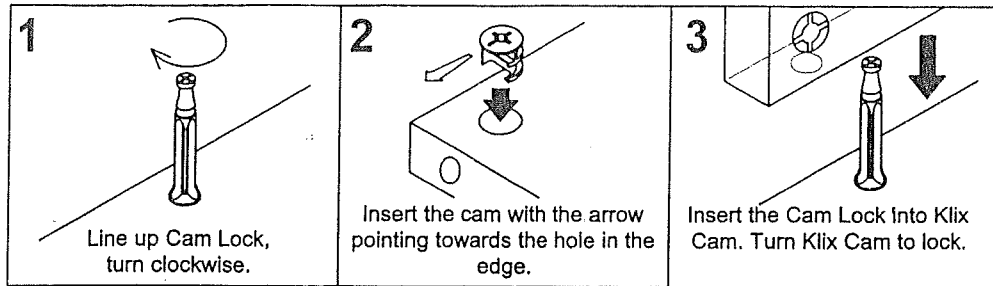

Option 2

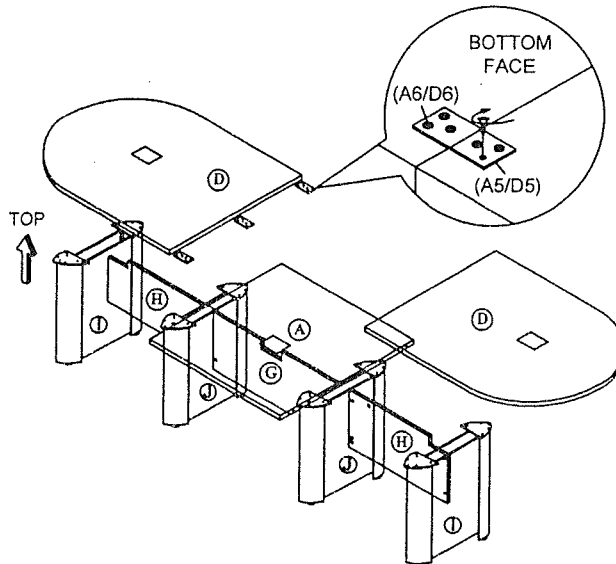

Attach the Flat-Bracket (A5/D5) to two Top Panel (D) and Top Panel (A) as shown. Tighten Screws (A6/D6) securely.

Attach Center Eleptical Base (J) to Modesty Panel (G) by using Cam Lock (J1/I1) and Klix Cam (J2/I2). Attach Modesty Panel (H) to Center Base (I) by using Cam Lock (J1/I1) and Klix Cam (J2/I2). Attach Eleptical Base (J) to Modesty Panel (H) by using Cam Lock (J1/I1) and Klix Cam (J2/I2). Attach Top Panel (A) & Top Panel (D) to Center Eleptical Base (I) & End Base (J) & Modesty Panel (G/H) by using Screw (J7/I8).

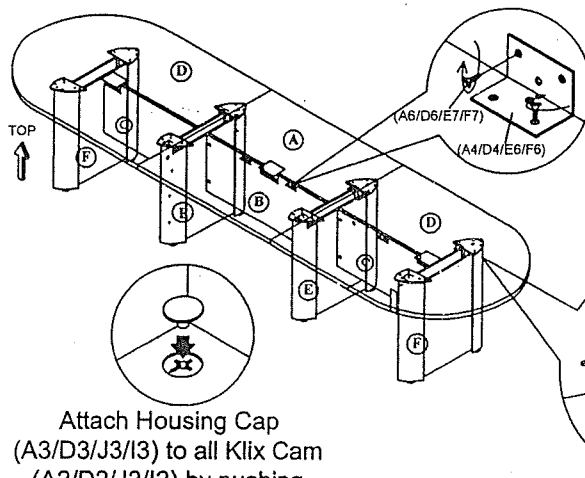

Attach the L-Bracket (A4/D4/J6/I5) from Top Panel (A/D) to Modesty Panel (G/H) and Eleptical Base (I) and Center Eleptical base (J) as shown. Tighten Screws (A6/D6/J7/I8) securely.

Attach Top Panel (A) & Top Panel (D) to Center Eleptical Base (I) & End Eleptical Base (J) & Modesty Panel (G/H) by using Screw (J7/I8).

Attach Housing Cap (A3/D3/J3/I3) to all Klix Cam (A2/D2/J2/I2) by pushing neck thought center of cam.

**RACE TRACK/BOAT SHAPE CONFERENCE TABLE**

1

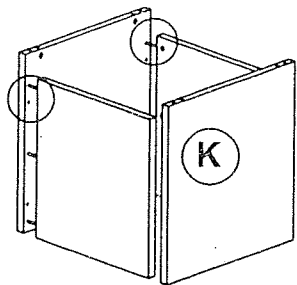

Attach Cube Base (K) by using Cam Lock (K1) and Klix Cam (K2).

2

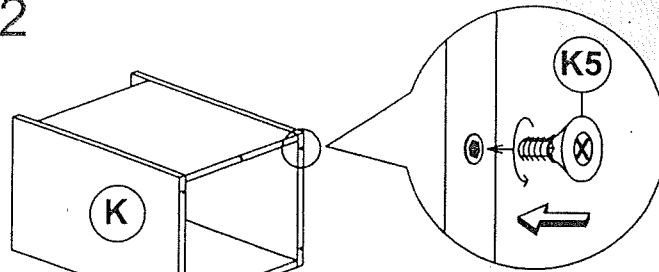

Screw Adjustable Glide (K5) into bottom of End Base (K).

3

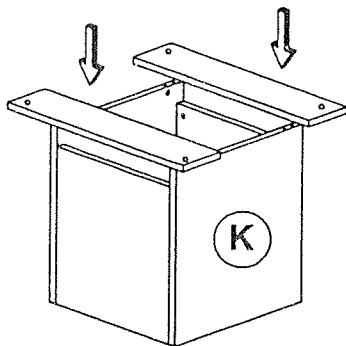

Attach Cube Base Support (K) by using Cam Lock (K1) and Klix Cam (K2).

4

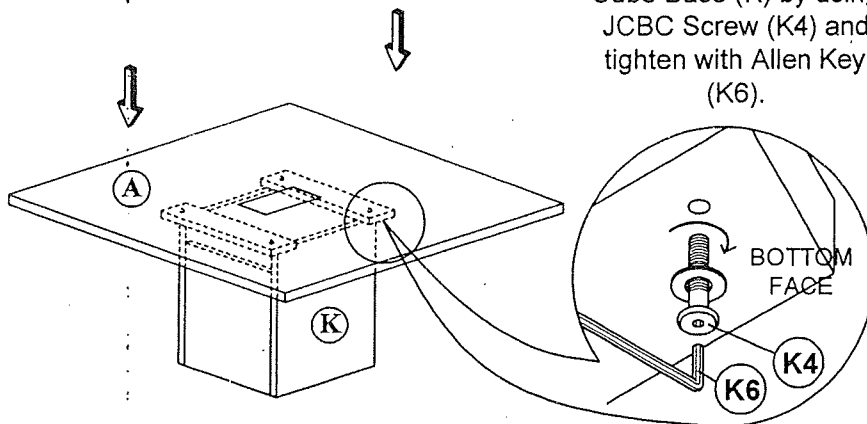

Attach Top Panel (A) to Cube Base (K) by using JCBC Screw (K4) and tighten with Allen Key (K6).

5 Option 3

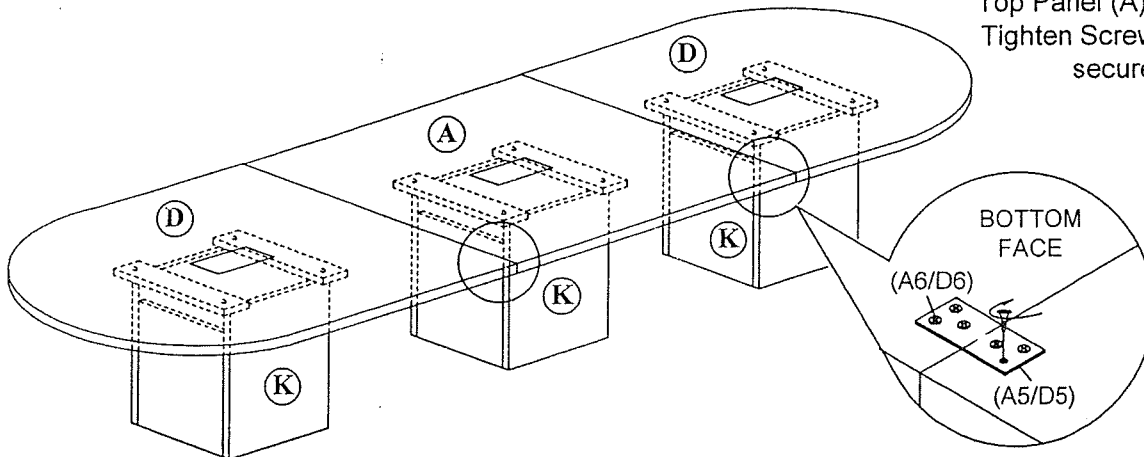

Attach the Flat-Bracket (A6/D6) to two Top Panel (D) and Top Panel (A) as shown. Tighten Screws (A5/D5) securely.